

Construction

Circulating pumps with a permanent magnet Synchronous motor.
Pump casing with suction and delivery connections with the same diameter and on the same axis (in-line).
Brass or cast iron unions on request.

Applications

For clean liquids, without abrasives, which are non-aggressive for the pump materials.
For heating plants.
For circulation plants.

Technical data

- Liquid temperature from +2 °C to +95 °C
- Ambient temperature from +2 °C to +40 °C
- Maximum permissible working pressure: 6 bar
- Storage: -20°C/+70°C max. relative humidity 95% at 40 °C
- Certifications: in conformity with CE requirements
- Sound pressure ≤ 43 dB (A).
- Minimum suction pressure: 0,3 bar at 95 °C
- Maximum glycol quantity: 40%
- EMC according to: EN 55014-1,
EN 61000-3-2,
EN 55014-2
- Connections: threaded ports ISO 228: G 1 1/2, G 2

Motor

- Synchronous motor with permanent magnet.
- Motor: 3000 rpm constant
- Standard voltage: single-phase 230 V (-10%;+6%)
- Frequency: 50 Hz
- Protection: IP 44
- Insulation class: H
- Class II appliance
- Overload protection (jammed rotor):
 - 1) automatic protection with electronic rotor release
 - 2) Overload thermal protector
- Cable : phases and neutral
- Constructed in accordance with: EN 60335-1, EN 60335-2-51

Characteristic curves

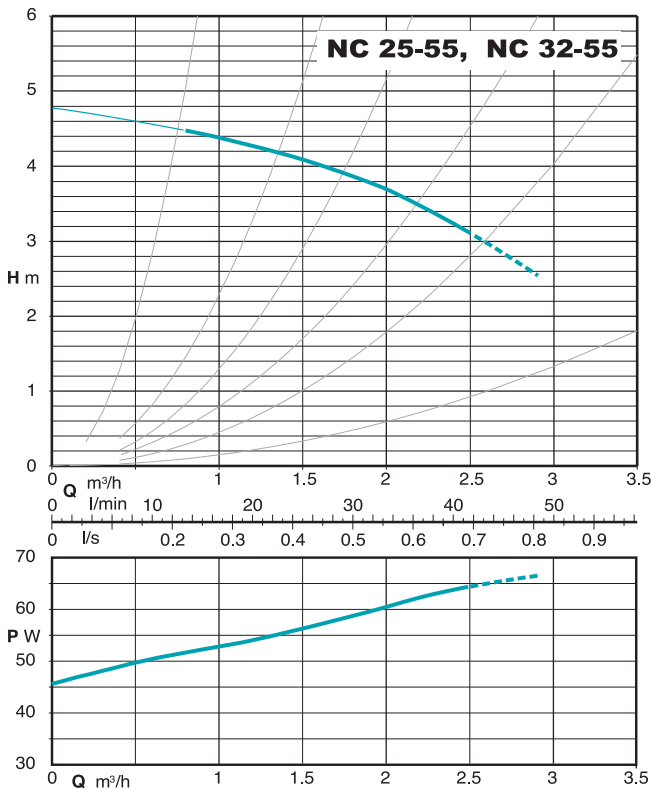
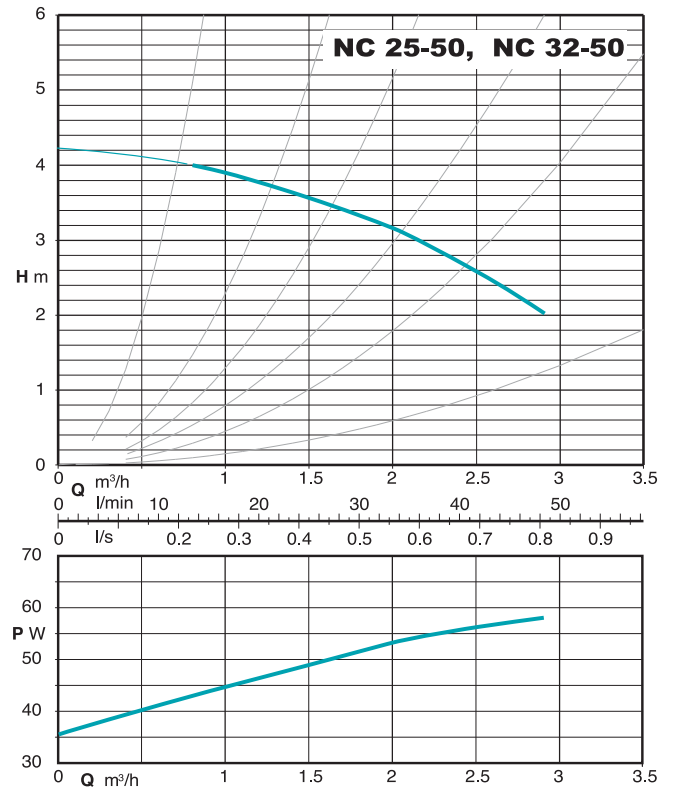
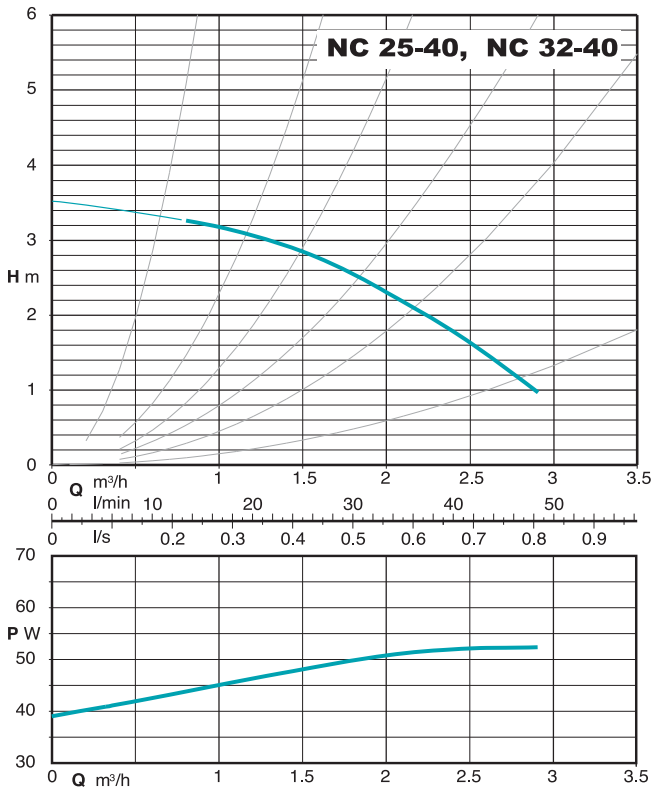

Dimensions and weights

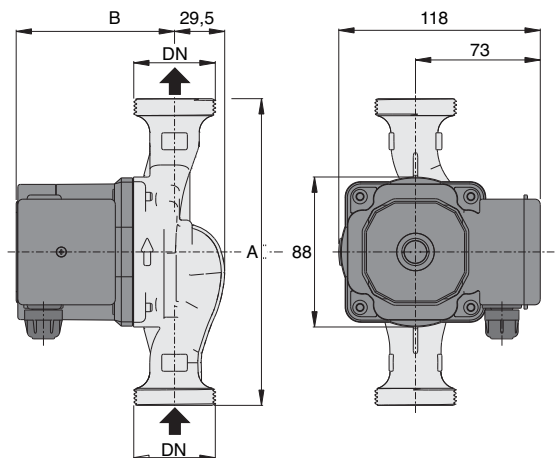

TYPE	DN	230V A	P1 W	mm		kg
				A	B	
NC 25-40/130	G 1 1/2	0,23	53	130	93	2,10
NC 25-40/180	G 1 1/2	0,23	53	180	93	2,25
NC 32-40/180	G 2	0,23	53	180	93	2,38
NC 25-50/130	G 1 1/2	0,26	58	130	103	2,39
NC 25-50/180	G 1 1/2	0,26	58	180	103	2,53
NC 32-50/180	G 2	0,26	58	180	103	2,67
NC 25-55/130	G 1 1/2	0,29	65	130	103	2,39
NC 25-55/180	G 1 1/2	0,29	65	180	103	2,53
NC 32-55/180	G 2	0,29	65	180	103	2,67

Materials

Component	Pos.	Material
Pump casing	1	Cast iron GJL 200 EN 1561
Impeller	2	Composite
Shaft	3	Stainless steel
Bearings	4	Spezialkohle
Thrust bearing	5	Ceramic
Rotor	6	Composite / Ferrite
Winding	7	Copper wire
Electronic card	8	-
Plug	9	Composite
Capacitor	10	-
Gasket	11	EPDM

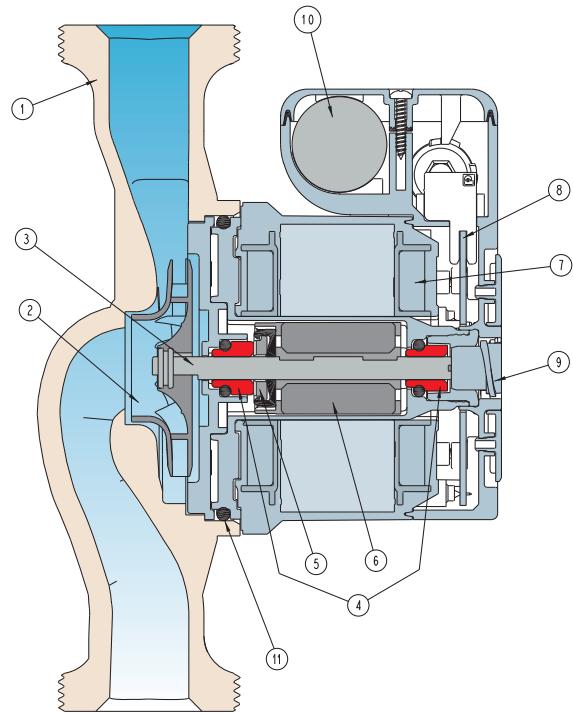

Installation

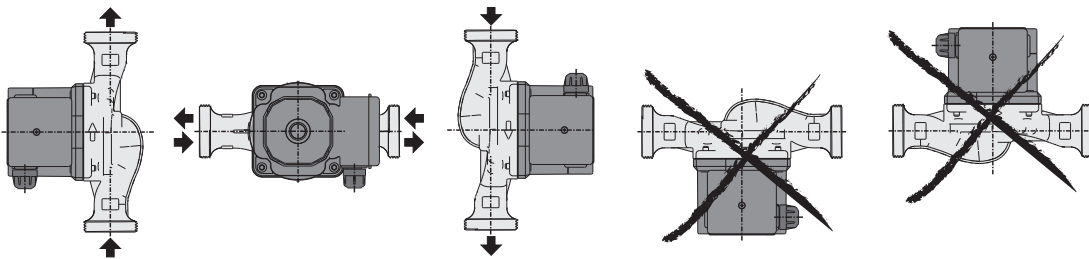

Terminal box arrangement

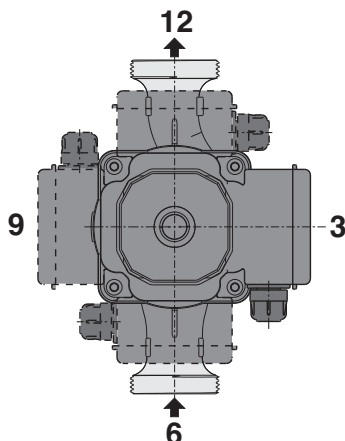

Unions

TYPE		DN	DN1
KIT G 1 1/2 - G 1	(NC. 25..)	G 1 1/2	G 1
KIT G 2 - G 1 1/4	(NC. 32..)	G 2	G 1 1/4

PERFORMANCE

The constant rotation speed of the synchronous motor allows for a reduction of the pressure variations under varying load losses. Moreover, the CALPEDA pumps are not affected by the temperature and the voltage mains. The traditional pumps can do it only by using sophisticated and expensive electronics.

CONSUMPTION

Consumption cut out by over 40%. With higher efficiency resulting in a lower absorbed current. This means lower consumption, guaranteed savings.

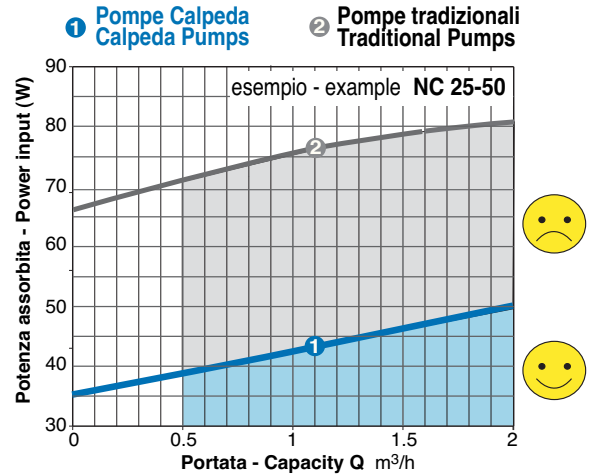
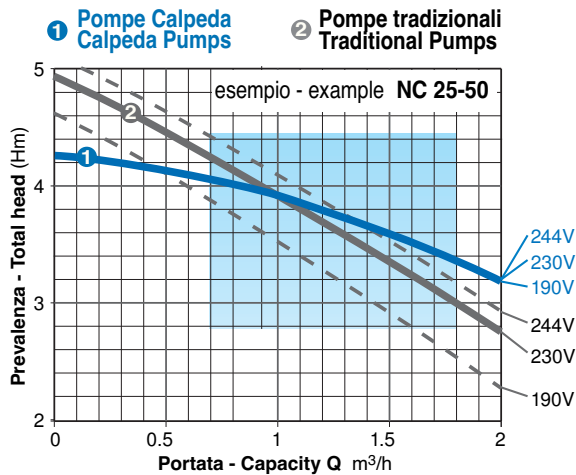

RELIABILITY

The **patented** "squared chamber" eliminates any possibility of rotor stoppage.

- 1- The operational characteristics of the synchronous motor allow to larger gap between stator and rotor, compared to an asynchronous motor, without any reduction of efficiency.
- 2- Being a permanent ceramic magnet, the rotor is less subject to limestone deposit than traditional metal rotors.
- 3- The "intelligent" electronics can sense any rotation difficulties: in such circumstances the motor is turned over several times at a higher torque than in traditional motors.

Always guaranteeing proper starting.

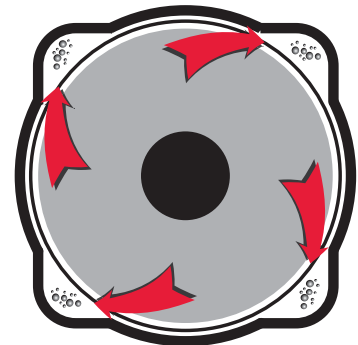

Patented

Escape routes for impurities inside the rotor chamber

SAFETY AND PRACTICALITY

Reliable electronics guarantee the perfect operation of the electropump with double electrical insulation Class II motor for greatest safety for users. The reduced temperatures of the motor provide for the use of materials, which allow for an electropump with high electrical insulation, by eliminating the risk of dangerous electrical losses when compared to traditional pumps.

Interchangeability

The CALPEDA circulating pump has the same axis base of other traditional pumps.

QUALITY/PRICE

An extraordinarily advantageous quality/price ratio.





Construction

Pump casing with suction and delivery connections with the same diameter and on the same axis (in-line).

Materials:

Pump casing	Cast iron
Impeller	Stainless steel
Shaft	Stainless steel

Applications

For clean liquids, without abrasives, which are non-aggressive for the pump materials (contents of solids up to 0.2%).

For heating, conditioning, cooling and circulation plants.

For civil and industrial applications.

When low noise operation is required.

Operating conditions

Liquid temperature from -10 °C to +120 °C (in short-time duty up to + 140 °C).

Ambient temperature up to 40 °C.

Maximum glycol quantity: 50% (Mixture with more than 20% glycol content require rechecking of the pumping data).

Maximum permissible working pressure 6/10 bar.

TYPE	Minimum suction pressure: bar		
	Temperature		
	50 °C	80 °C	110 °C
NC 40	0,05	0,8	1,4
NC 50	0,3	1	1,6
NC 65	0,3	1	1,6
NC 80	0,3	1	1,6

Motor

2-4-pole induction motor, 50 Hz.
Three adjustable speeds.

NC: three-phase 230V or 400 V.

NCM: single-phase 230 V.

Insulation class H.

Protection IP 43.

Installation

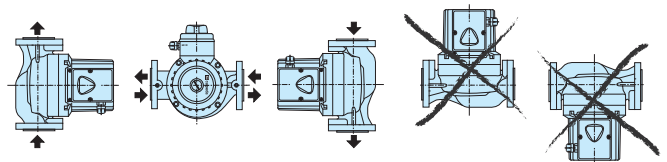

Cross section drawings

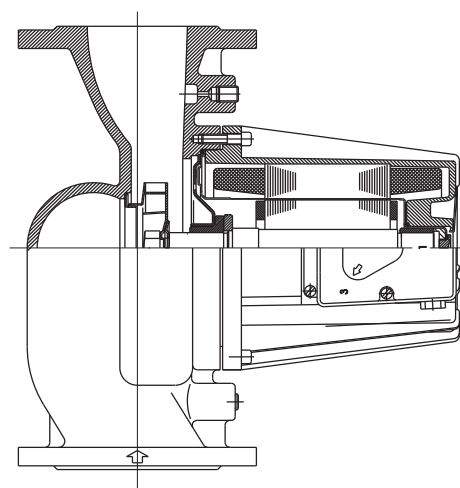

Designation

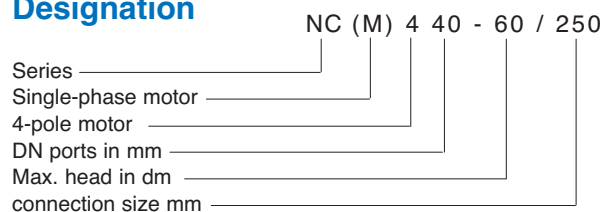

Coverage chart

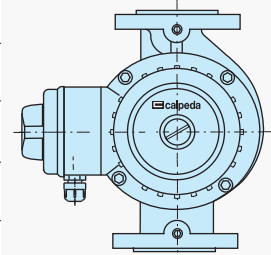
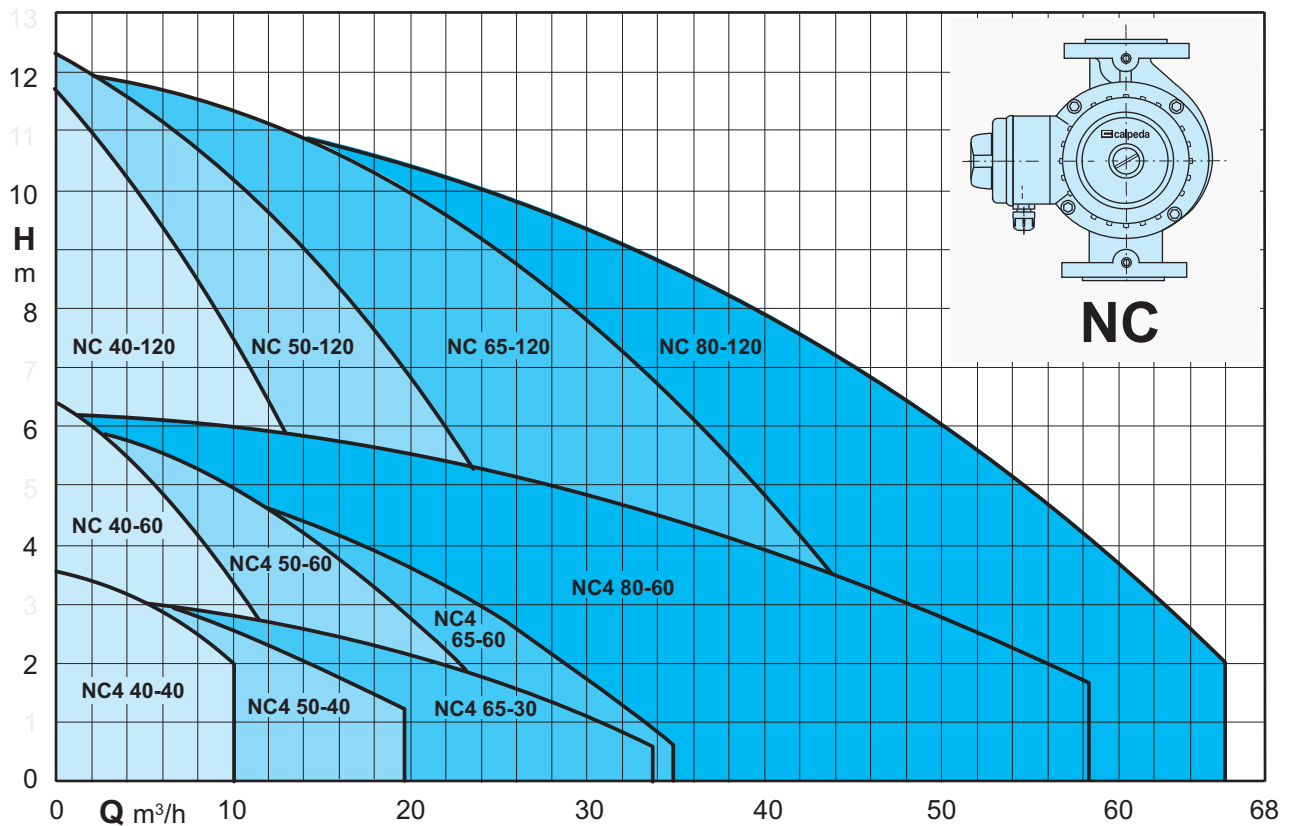

NC

Tolerances according to ISO 9906, annex A.

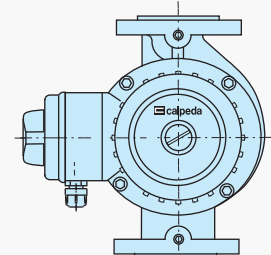
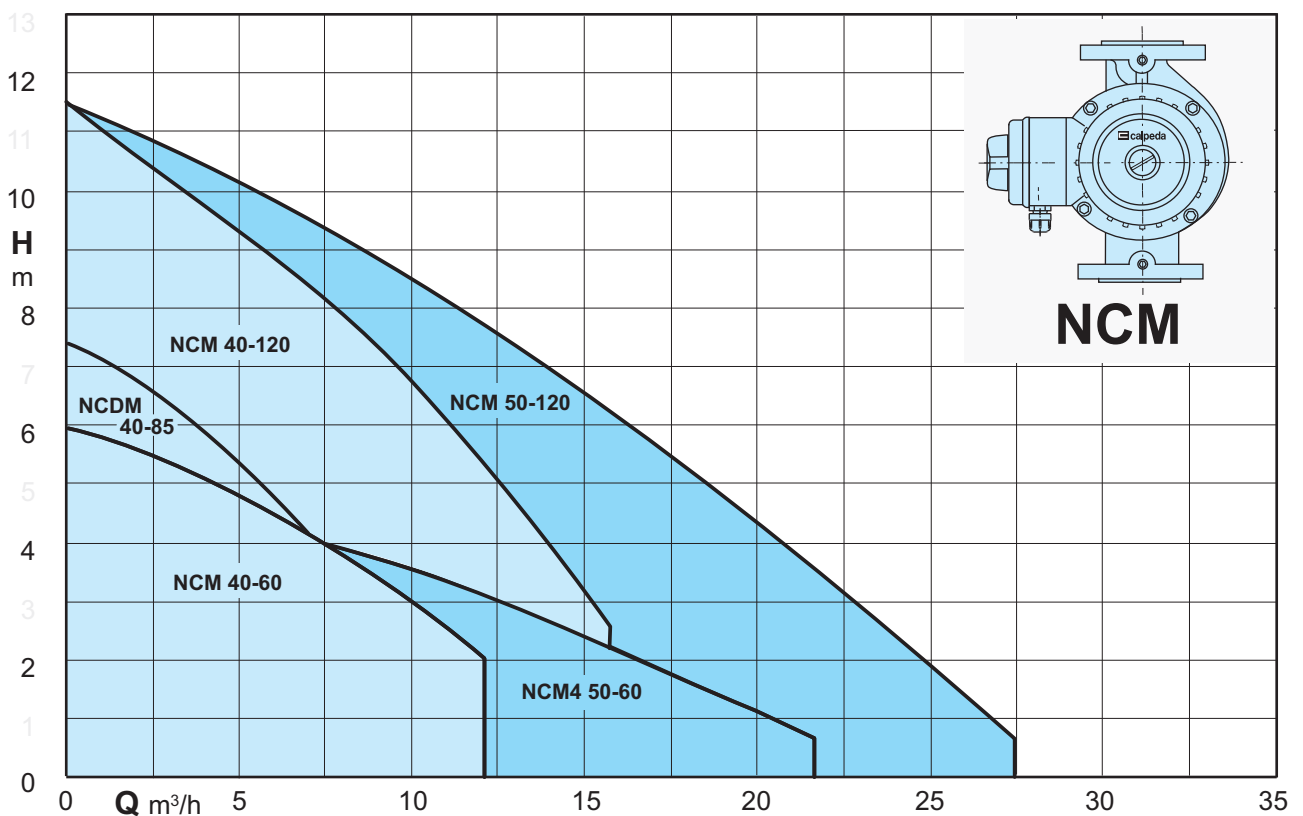

NCM

Tolerances according to ISO 9906, annex A.

Characteristic curves, dimensions and weights

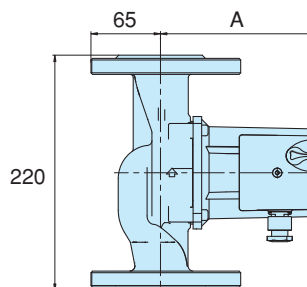
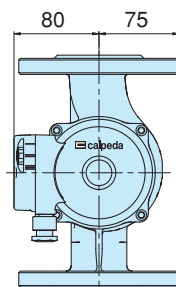
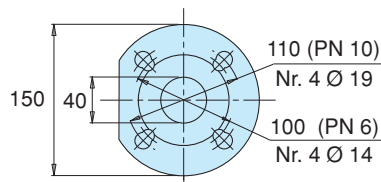
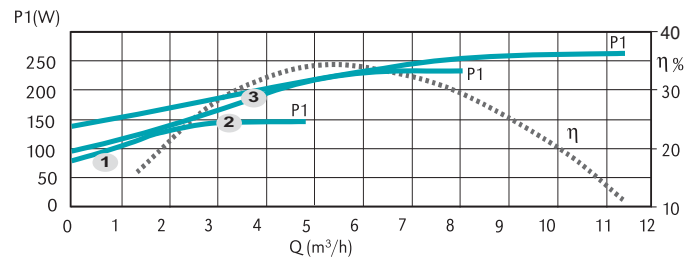
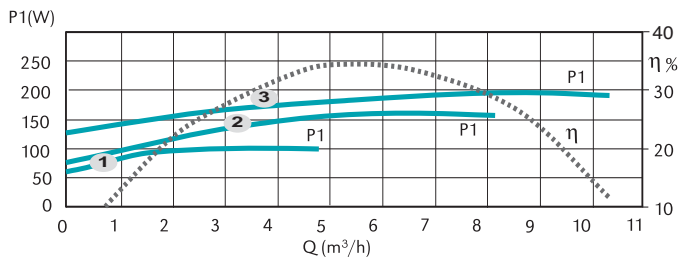
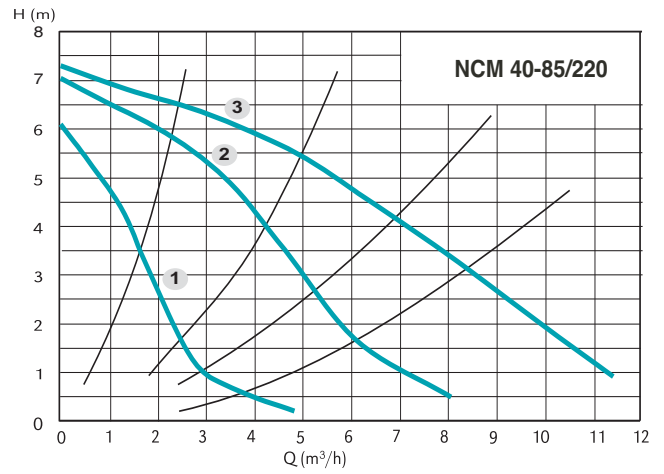
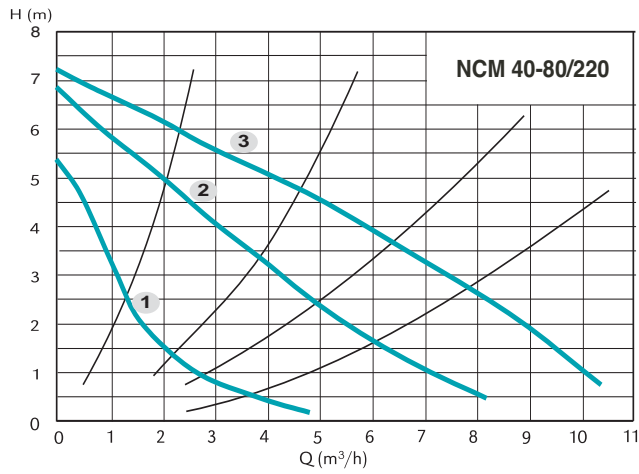

TYPE	DN PN		N° Poli 2 4	Pos.	1/min	P1 (W)	1x 230 V [A]	A [mm]	[kg]
	DN	PN							
NCM 40-80/220	40	6/10	✓	3	-	210	0,95	150	8,1
				2	-	176	0,80		
				1	-	107	0,49		
NCM 40-85/220	40	6/10	✓	3	-	277	1,20	175	8,8
				2	-	250	1,16		
				1	-	172	0,85		

Characteristic curves, dimensions and weights

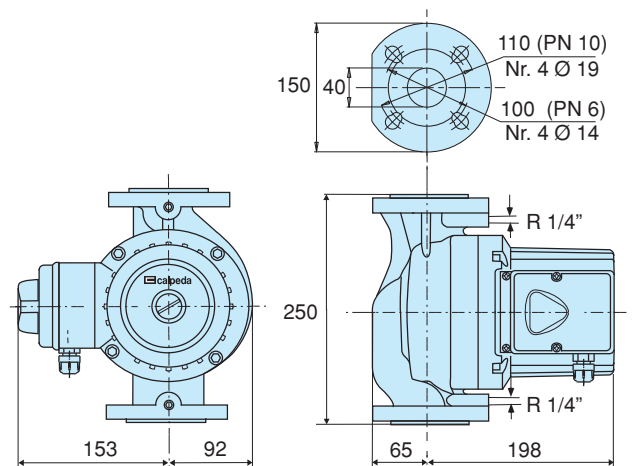
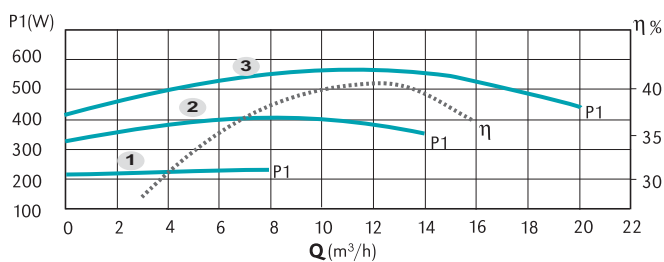
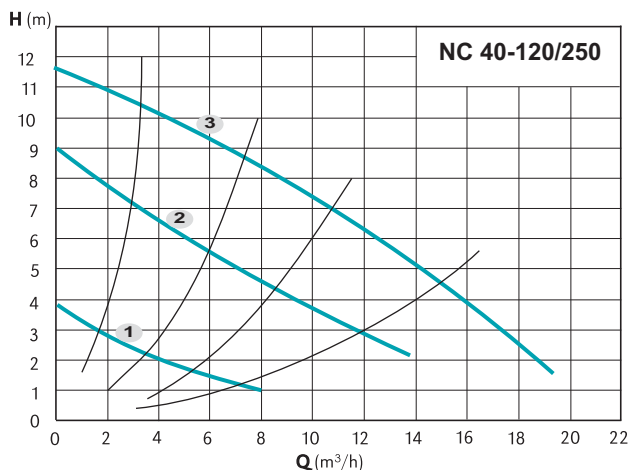
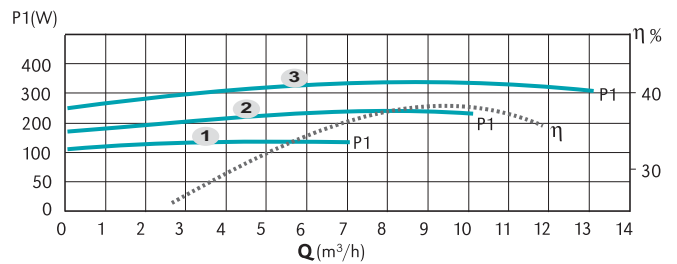
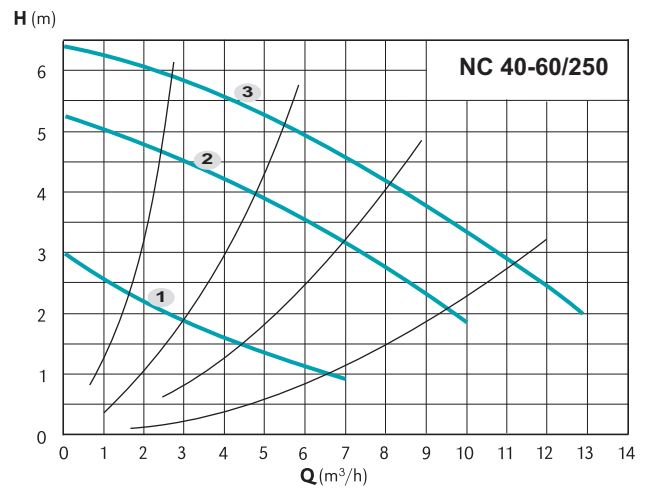
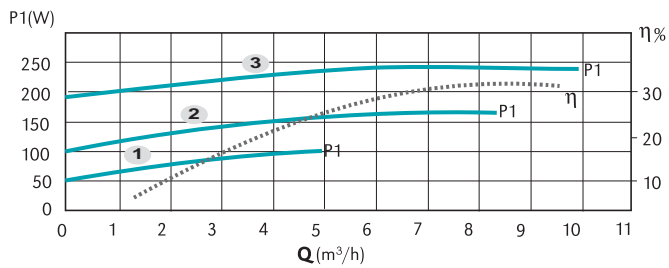
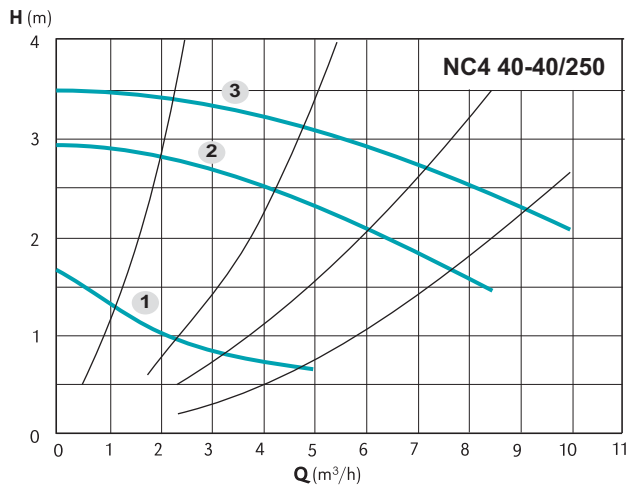

TYPE	DN	PN	N° Poli		Pos.	1/min	P1 (W)	3x 400 V [A]	[kg]
			2	4					
NC4 40-40/250	40	6/10	✓		3	1440	240	0,76	17,0
						1200	160	0,24	
						660	100	0,11	
NC 40-60/250	40	6/10	✓		3	2790	320	0,74	17,5
						2240	240	0,36	
						1440	140	0,18	
NC 40-120/250	40	6/10	✓		3	2820	560	1,16	19,0
						2200	400	0,64	
						1250	220	0,26	

Characteristic curves, dimensions and weights

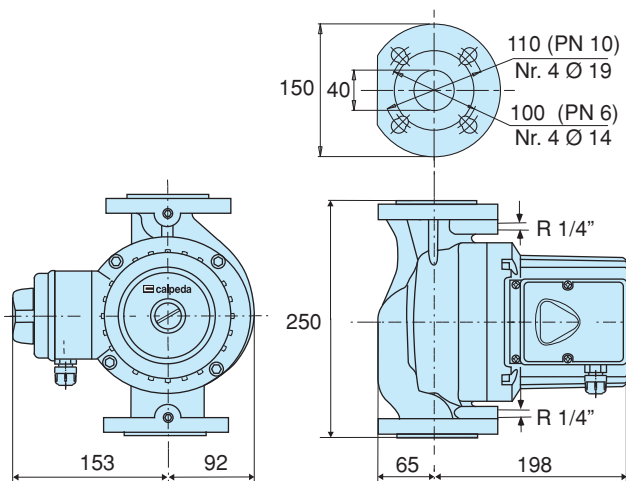
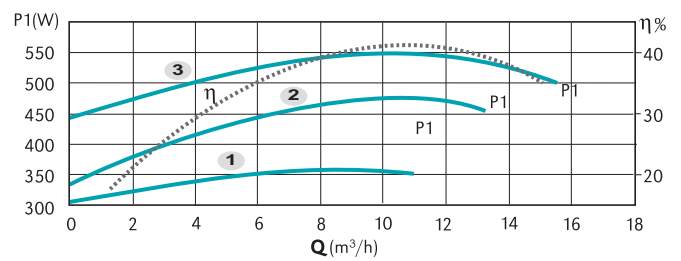
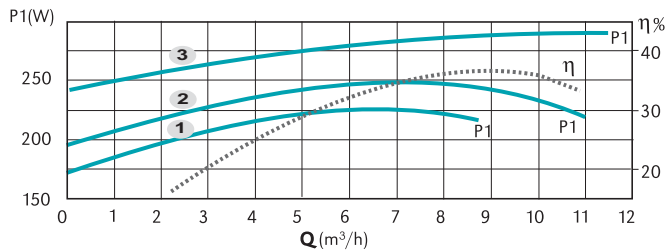
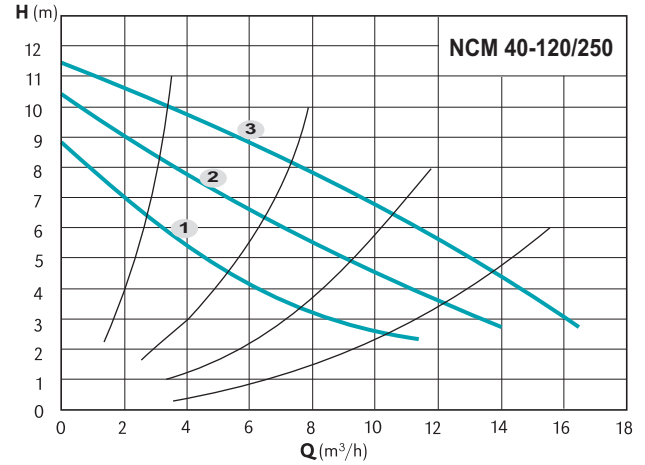
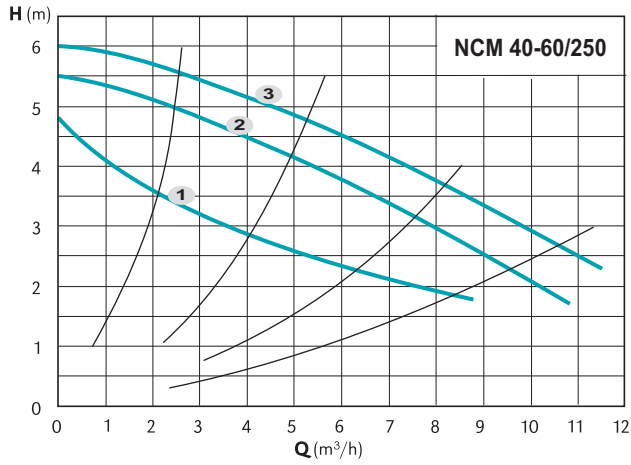

TYPE	DN	PN	N° Poli		Pos.	1/min	P1 (W)	1x 230 V [A]	[kg]
			2	4					
NCM 40-60/250	40	6/10	✓		3	2690	285	1,20	17,5
					2	2360	245	1,18	
					1	1820	225	1,15	
NCM 40-120/250	40	6/10	✓		3	2750	550	2,35	19,0
					2	2100	475	2,30	
					1	1270	355	1,85	

Characteristic curves, dimensions and weights

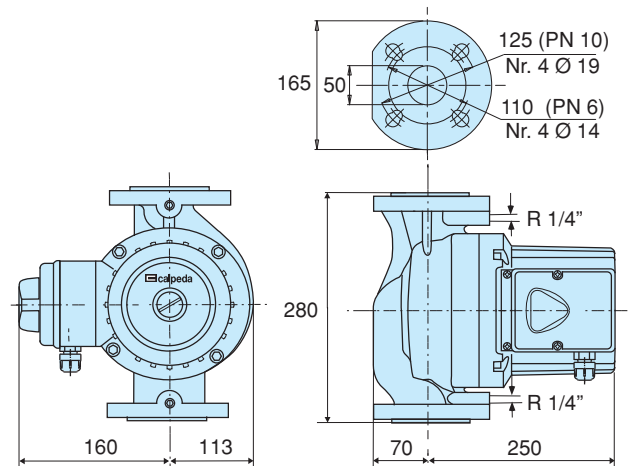
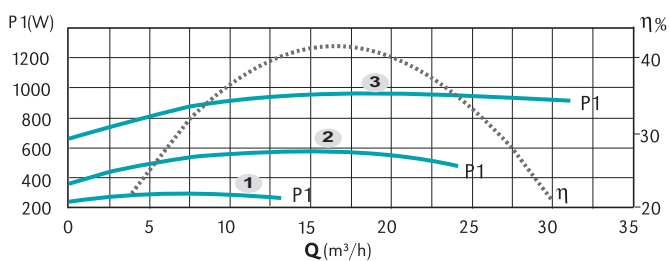
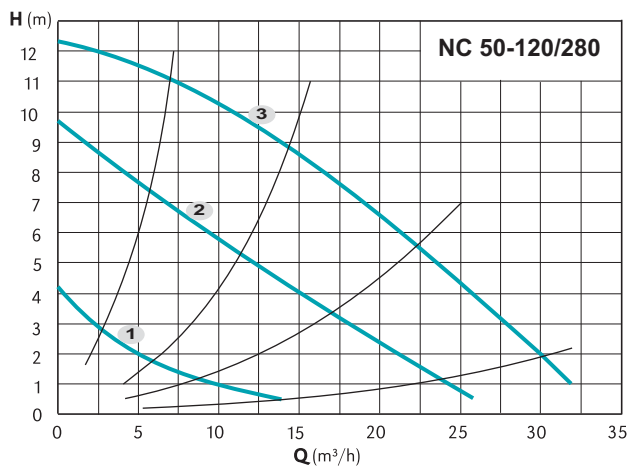
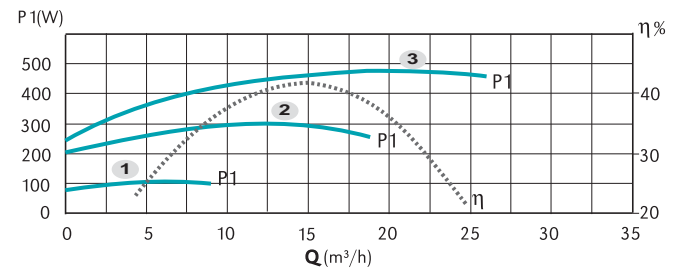
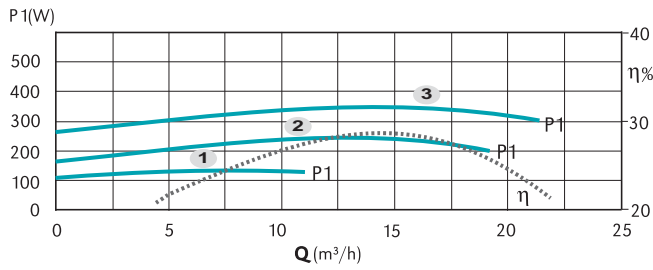
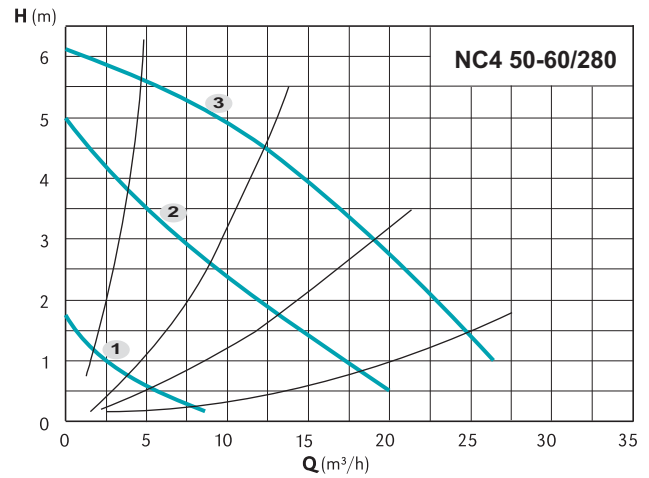
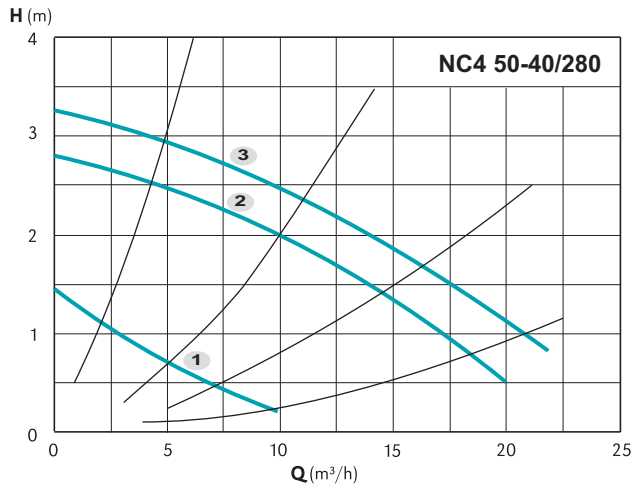

TYPE	DN	PN	N° Poli		Pos.	1/min	P1 (W)	3x 400 V [A]	[kg]
			2	4					
NC4 50-40/280	50	6/10	✓		3	1450	340	1,05	24,0
					2	1220	240	0,44	
					1	620	120	0,22	
NC4 50-60/280	50	6/10	✓		3	1400	470	1,15	24,0
					2	1000	300	0,55	
					1	560	100	0,20	
NC 50-120/280	50	6/10	✓		3	2800	950	1,73	24,0
					2	2330	540	1,05	
					1	1270	265	0,46	

Characteristic curves, dimensions and weights

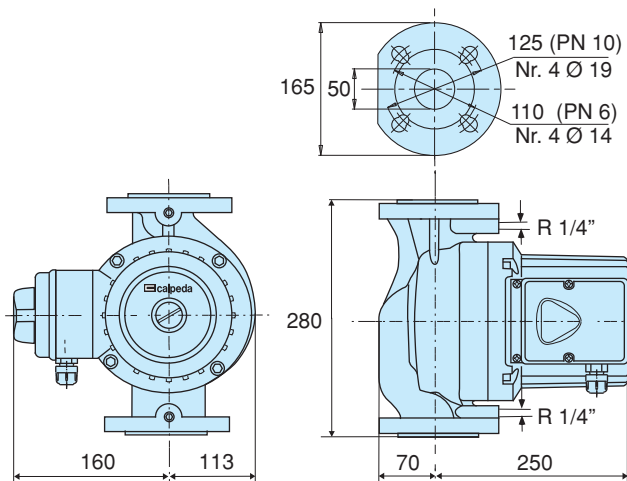
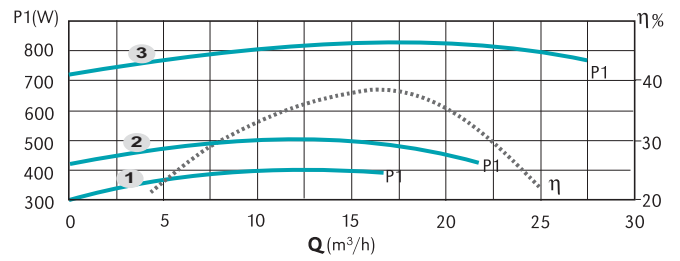
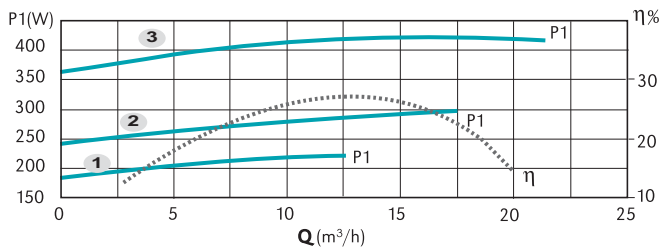
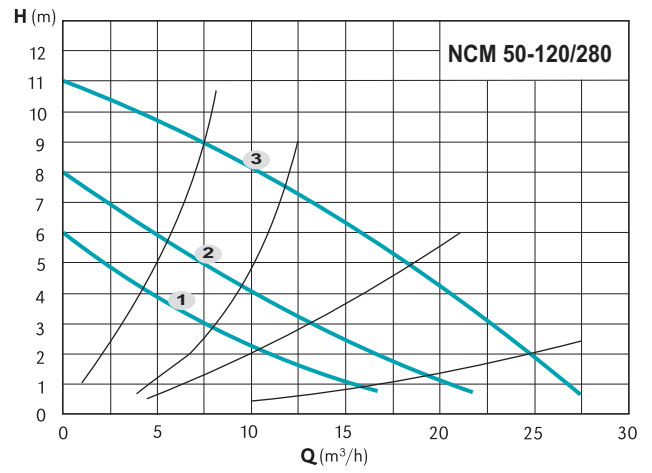
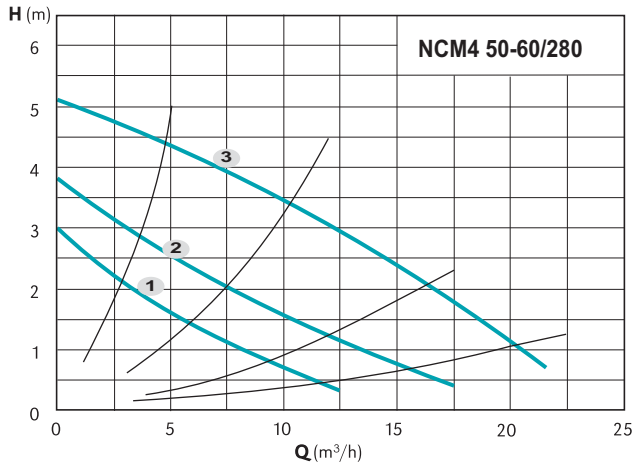

TYPE	DN PN	N° Poli 2 4	Pos.	1/min	P1 (W)	1x 230 V	
						[A]	[kg]
NCM4 50-60/280	50 6/10	✓	3	1260	415	1,8	24,5
			2	1030	300	1,3	
			1	740	230	1,0	
NCM 50-120/280	50 6/10	✓	3	2720	830	3,6	24,5
			2	1870	480	2,1	
			1	1450	390	1,7	

Characteristic curves, dimensions and weights

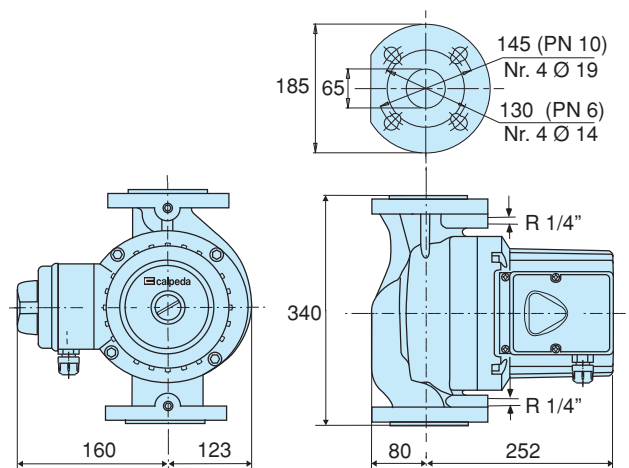
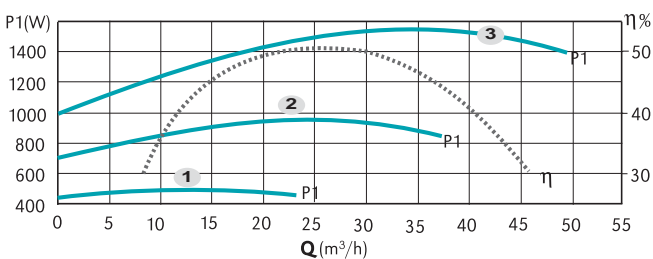
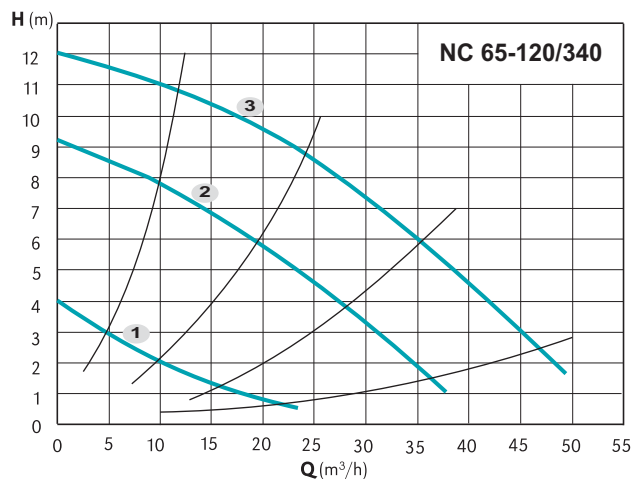
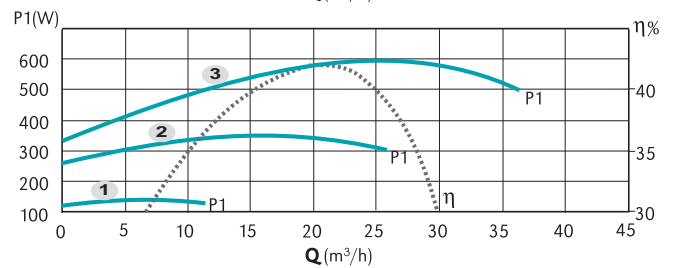
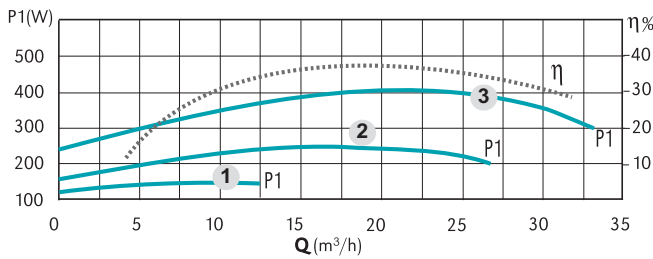
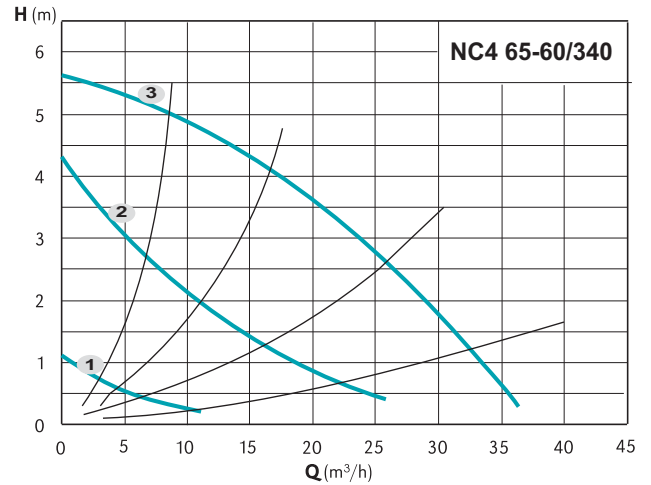
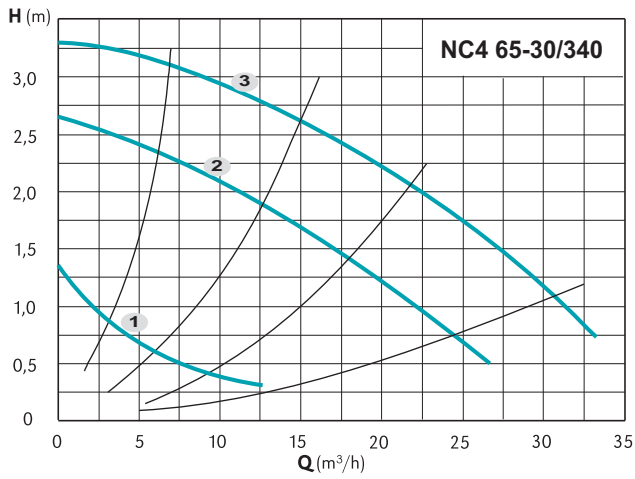

TYPE	DN PN	N° Poli 2 4	Pos.	1/min	P1 (W)	3x 400 V [A]	[kg]
NC4 65-30/340	65 6/10	✓	3	1430	400	1,10	29,0
			2	1150	260	0,50	
			1	600	120	0,22	
NC4 65-60/340	65 6/10	✓	3	1370	600	1,25	29,0
			2	950	360	0,64	
			1	450	120	0,22	
NC 65-120/340	65 6/10	✓	3	2810	1560	2,80	31,0
			2	2200	960	1,70	
			1	1250	460	0,84	

Characteristic curves, dimensions and weights

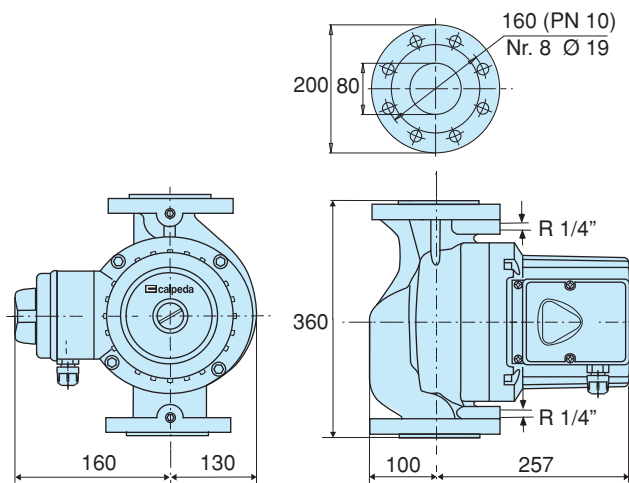
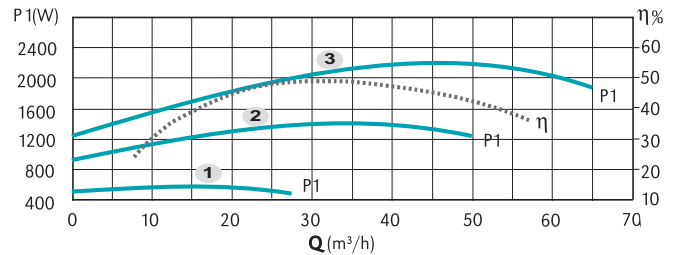
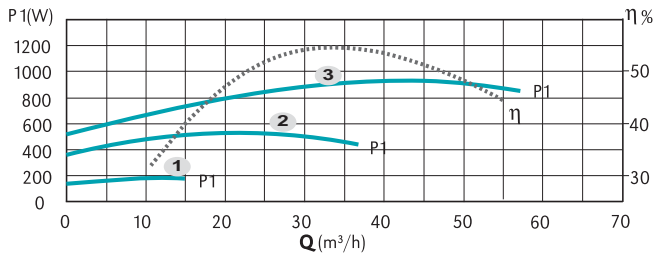
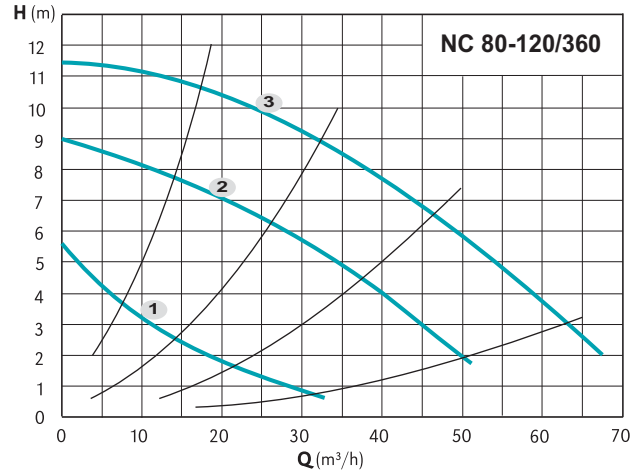
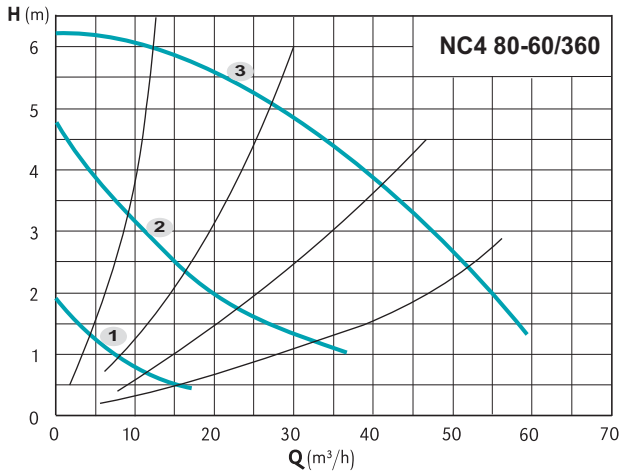

TYPE	DN	PN	N° Poli	Pos.	1/min	P1 (W)	3x 400 V	
							[A]	[kg]
NC4 80-60/360	80	10	✓	3	1350	960	2,20	33,5
				2	1000	560	1,10	
				1	600	200	0,38	
NC 80-120/360	80	10	✓	3	2800	2200	3,80	34,5
				2	2160	1400	2,40	
				1	1200	550	1,05	